

**LW-C Series**

**Switch-Mode DC Regulated Power Supply**

**User Manual**

# Table of Contents

<b>General Safety Overview</b> .....	1
<b>1. Product Description</b> .....	2
1.1 Introduction .....	2
1.2 Features .....	3
1.3 Standard Accessories .....	3
1.4 Product Specifications .....	4
1.5 Panel Description .....	5
1.6 Keypad Description .....	7
<b>2 Operating Instructions</b> .....	8
2.1 Front Panel Operating Instructions .....	8
2.2 Input Method .....	9
2.2-1 Numeric Key Input Method .....	9
2.2-2 Knob Input Method .....	11
2.3 Storage/Retrieval Operations .....	12
2.3-1 Storage Operation .....	12
2.3-2 Retrieval Operation .....	12
2.4 Function Settings .....	13
2.4-1 Status Value Display .....	13
2.4-2 Continuous Time Setting .....	14
2.4-3 Lock Function .....	15
2.4-4 Overvoltage Cancellation .....	15
2.5 Protection Functions .....	15
2.6 Operation Mode Description .....	15
2.6-1 Constant Voltage Operation Mode .....	15
2.6-2 Constant Current Operation Mode .....	16

2.6-3 Constant Voltage/Constant Current State Switching .....	16
2.7 Remote Compensation Function Usage .....	17
<b>3 Remote Control</b> .....	<b>18</b>
3.1 Interface .....	18
3.2 Communication Settings .....	19
3.3 Host Computer Control Interface .....	20
3.4 Communication Format .....	20
<b>4 Common Fault Handling and Maintenance</b> .....	<b>21</b>
<b>5 Monitoring Assistant Software User Instructions</b> .....	<b>23</b>

## **General Safety Overview**

Carefully read the following safety precautions to avoid personal injury and prevent damage to this product or any products connected to it. To avoid potential hazards, be sure to use this product as specified. Only qualified personnel should perform maintenance procedures.

**Use the appropriate power cord. Please use the dedicated power cord for this product.**

**Use the correct voltage setting. Before turning on the power, ensure that the line selector is set to the appropriate position for the power supply being used.**

**Ground the product. This product is grounded through the grounding wire of the power cord. To avoid electric shock, the grounding wire must be connected to the earth. Before connecting to the input or output terminals of this product, be sure to properly ground the product.**

**Disconnect the power. The power switch can disconnect the power to the product. Please refer to the instructions regarding its location, and do not obstruct the power switch.**

**Never operate with the cover open. Do not run this product with the outer cover or panel open.**

**Do not operate if you suspect the product is faulty. If you suspect this product is damaged, have it inspected by qualified maintenance personnel.**

**Keep away from exposed circuits. Do not touch exposed wires and components when the power is on.**

**Use qualified fuses. Only use the fuse types and ratings specified for this product.**

**Do not operate in damp or corrosive environments. Otherwise, it may lead to power supply failure or accelerate damage.**

**Please keep the surface of the product clean and dry. If cleaning is necessary, first disconnect the power, and use a damp cloth with mild detergent and clean water.**

**Please ensure proper ventilation. Do not block the ventilation openings on the side and rear panels.**

**Do not operate in flammable or explosive environments.**

## **Symbols and terminology on the product**

The following terms may appear on the product:

A 'Danger' indicates an injury that will occur immediately upon reading this label.

B 'Warning' indicates an injury that will not occur immediately upon reading this label.

C 'Caution' indicates a potential hazard to this product or other property.

The following symbols may appear on the product

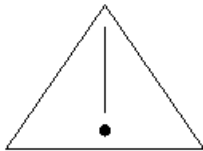

Caution

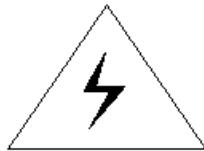

Warning High Voltage



Protective Ground Terminal

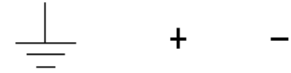

Ground Terminal Positive Terminal Negative Terminal

## 1. Product Description

### 1.1 Introduction

This series of products is a high-precision single-output programmable DC switching power supply, with adjustable current and voltage, high output power, compact size, and multiple operating modes. The entire system is fully controlled by a microprocessor (MPU) and can easily connect to a computer (PC) via communication interfaces (USB) or (RS-485), meeting users' needs for automated testing and remote control. Data input is entirely done via the keyboard, which is fast, accurate, and convenient; manual adjustments can also be made for continuous input

regulation. It can be widely used in electronic product development, device testing, product aging, the communications industry, laboratories, and research institutions.

## 1.2 Features

01 High precision and high resolution 10mV/10mA

02 High brightness LCD display

03 Convenient and fast operation and settings, digital key input and analog adjustment knob input

Overload, overvoltage protection, overcurrent protection, overtemperature protection

One-key lock function, effectively preventing misoperation

Built-in buzzer for prompts or warnings

Low noise, long lifespan temperature-controlled fan

Can display load power value, resistance value, and has low resistance measurement function

Supports USB interface and 485 interface

Constant voltage and constant current automatic switching

Stores/retrieves 6 sets of voltage and current values

Automatically recalls the voltage and current values set before shutdown upon power-on

Compensates for output line voltage drop loss, stabilizing voltage at the load end

## 1.3 Standard accessories

Power main unit	1 unit
Input power cable	1 piece
CD	1 piece
User manual	1 copy
Warranty certificate	1 piece

## 1.4 Product specifications

型号	LW-3020C	LW-3030C	LW-3050C	LW=6010C	LW-6020C	LW-6030C	LW-12010C	LW-3005C
<b>额定直流输出 (0°C-45°C)</b>								
电压	0-30V	0-30V	0-30V	0-60V	0-60V	0-60V	0-120V	0-300V
电流	0-20A	0-30A	0-50A	0-10A	0-20A	0-30A	0-10A	0-5A
过压保护	0-31V	0-31V	0-31V	0-61V	0-61V	0-61V	0-121V	0-301V
过流保护	0-21A	0-31A	0-51A	0-11A	0-21A	0-31A	0-11A	0-6A
<b>电压输出</b>								
电源效应	≤0.05%+10mv							
负载效应	≤0.1%+10mv							
涟波和噪音	10mVrms, 50mVpp							
温度系数	≤300ppm/°C							
设定精度	± (0.03% of reading + 10mv)							
设定分辨率	10mv							
<b>电流输出</b>								
电源效应	≤0.05%+10mA							
负载效应	≤0.1%+10mA							
涟波和噪音	10mA rms							
设定精度	± (0.03% of reading + 10mA)							
设定分辨率	10mA							
<b>显示</b>								
电压	4 digits display							
电流	4 digits display							
电压分辨率	10mV							
电流分辨率	10mA							
读数精度	± (0.1% of reading + 10mV); ± (0.1% of reading + 10mA)							
保护	过载保护, 过压保护, 过流保护, 过温度保护							
接口	USB接口, 485接口							
存储输出	6组							
绝缘度	输出端子与机壳或其它端子间: ≤60VDC							
操作环境	室内使用 环境温度: 0-40°C 相对湿度: ≤80%							
电压输入	AC220V ± 10%, 50/60Hz							
附件	使用手册一份, 电源线1份							
尺寸	380(D) × 260(W) × 155(H) mm							
重量	12KG							

## 1.5 Panel description

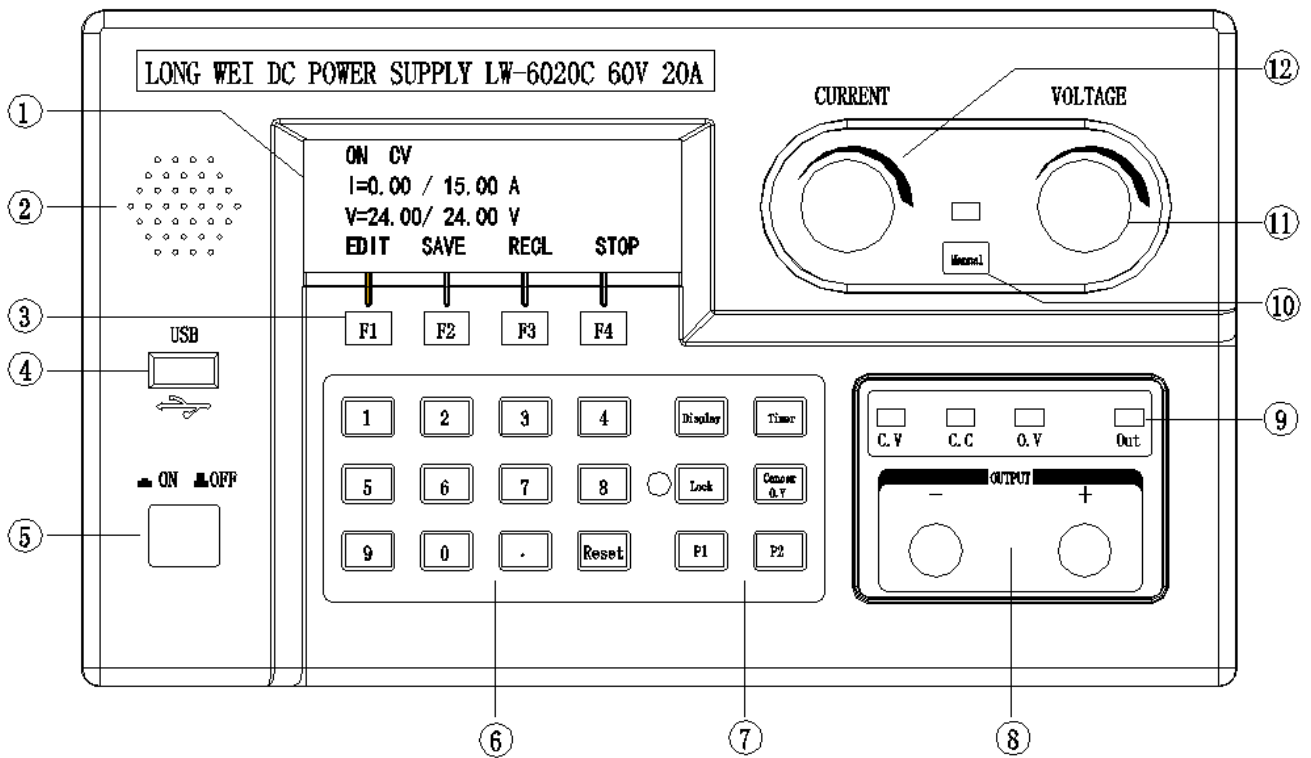

### Front panel diagram

1. Display screen for setting operations, showing the operation process and instructions; during operation, displays the power status and various values
2. Buzzer, sounds an alarm when the set working time is completed
3. Indicator function keys (4), pointing to the four operation instructions at the bottom of the LCD screen, executing corresponding operations
4. USB interface, can be connected to a computer, with the upper computer software provided on the computer to control the power supply
5. Power switch, to turn on or off the power input
6. Digital keys, for setting parameter values of the power supply, such as voltage, can press the digital keys to input values



- 7. Function keys, detailed power parameters and status display, working time settings, locking and over-voltage cancellation functions
- 8. Output terminals, power output current
- 9. Indicator lights, indicating the power status, Constant Voltage (C.V), Constant Current (C.C), Over Voltage (O.V), and output status (Out)
- 10. Manual input keys and indicator lights, pressing can switch to manually adjust current and voltage
- 11. Voltage adjustment knob, adjusts voltage when in manual input mode
- 12. Current adjustment knob, adjusts current when in manual input mode

Rear panel diagram

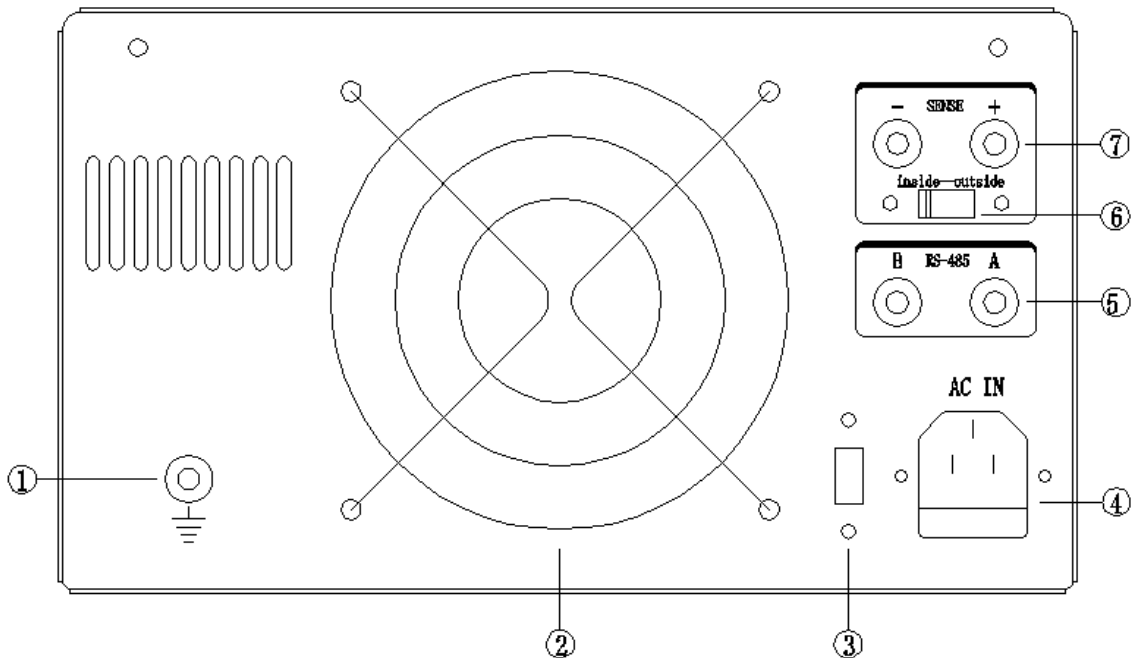

1. Power grounding terminal, when the panel output positive or negative needs to be grounded, it can be connected to this grounding terminal.

2. Temperature-controlled fan, the fan starts rotating when the temperature reaches the starting temperature
3. 110V/220V switch, default is none, optional available
4. Power socket (including fuse holder)
5. RS485 interface, A and B terminals are for 485 communication A and B
6. Remote compensation switch, switch to compensate for output line voltage drop when compensation is needed
7. Remote compensation terminal, used to connect to both ends of the load when compensation for output line voltage drop is needed

## 1.6 Keyboard description

### Key description

There are a total of 22 keys on the front panel (excluding the power key), which directly execute basic functions.

Key name	Function
F1 F2 F3 F4	Points to the operation prompt at the bottom of the LCD screen, generating operation execution
0	Input number 0
1	Input number 1
2	Input number 2
3	Input number 3
4	Input number 4
5	Input number 5
6	Input number 6

7	Input number 7
8	Input number 8
9	Input number 9
.	Input decimal point
Reset	Reset value
Display	Power status, output value display
Timer	Working duration setting
Lock	Lock keyboard
Cancel O.V	Cancel overvoltage
P1 P2	Spare key, default no function

## 2. Operating instructions

### 2.1 Front panel operating instructions

(1) The units of voltage and current mentioned in this instrument and user manual are in volts V and amperes A; the units of power and resistance are in watts W and ohms  $\Omega$ .

(2) This instrument is factory set to front panel operation mode. When the power is turned on, the required instrument settings can be made on the panel.

(3) When powered on, the LCD screen displays **Main interface** introduction (example):

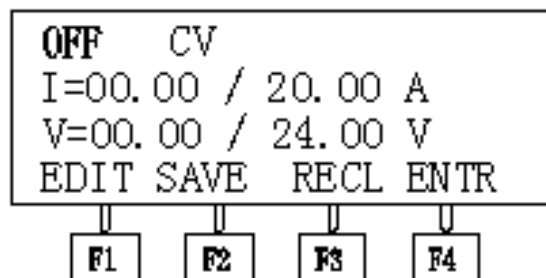

① **OFF: Power output status, with ON working and OFF shutting down.**

② **CV:** The power supply operating status includes CV constant voltage, CC constant current, overvoltage OV, and overcurrent OCP.

③ **I=00.00 / 20.00 A:** Displays the actual output current and set current value of the power supply, where the first part 00.00 is the actual output value, and the second part 20.00 is the set output current value, in Amperes A.

④ **V=00.00 / 24.00V:** Displays the actual output voltage and set voltage value of the power supply, where the first part 00.00 is the actual output voltage value, and the second part 24.00V is the set output voltage value, in Volts V.

**Note:** F1, F2, F3, F4 are four indicator function keys that point to the operational functions at the bottom of the LCD screen. Pressing them will result in corresponding operational changes. For example, pressing **【F1】** will enter the power supply parameter setting interface for parameter configuration.

## 2.2 Input Methods

The front panel provides two input methods: numeric key input and knob input.

**Numeric key input:** Use the numeric keys to input the desired value, the F4 key corresponds to the display screen Enter, and press F4 to confirm. If there is an error in the data input, press the Reset key to clear the current value and re-enter the data.

**Knob input:** In practical applications, it is sometimes necessary to continuously adjust the output voltage or current, in which case the analog adjustment knob can be used. The knob on the panel is a multi-turn potentiometer; turning it clockwise increases the output value, while turning it counterclockwise decreases it.

### 2.2-1 Output voltage, output current, and overvoltage, overcurrent protection settings (numeric key input method)

① Connect the power cord properly, and after pressing the power switch, the display screen will power on as shown below (example):

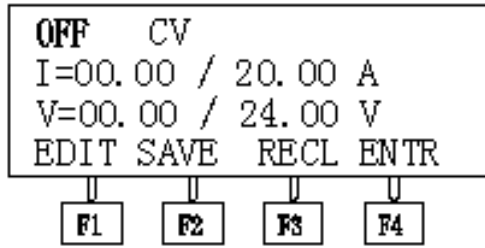

\* At this time, the display screen shows the last working shutdown settings of voltage 24.00V and current value 20.00A. If no changes are needed, you can directly press **【 F4 】** key, corresponding to the display screen ENTR, and the power supply will start outputting and begin operation.

② If you need to reset the parameter values, press **【 F1 】** (corresponding to EDIT), and the display screen will enter the settings interface, as shown below:

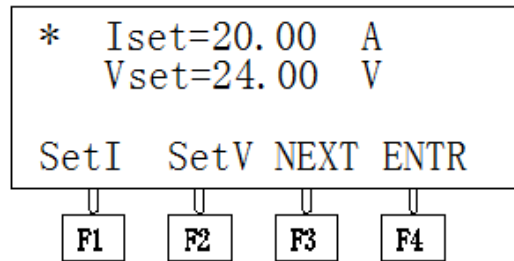

At this time, pressing **【 F1 】** or **【 F2 】** allows you to select to set the **output current** or **output voltage** value, with a flashing \* symbol indicating the setting item. You can then input the desired value using the numeric keypad. If you want to clear and reset, press the **【 Reset 】** key and re-enter. If the input value exceeds the power supply range, 'RESET AGING' will be displayed as a reminder, requiring re-entry of the settings.

Press **【 F3 】** to switch the display to the parameter settings interface, as shown below:

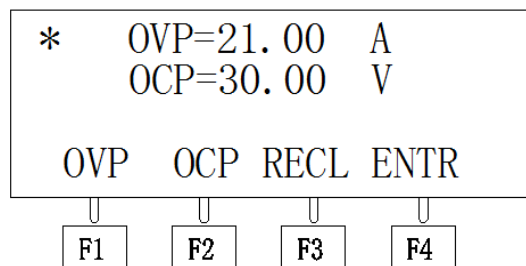

At this point, pressing **【 F1 】** or **【 F2 】** allows you to select to set **overvoltage protection** or **overcurrent protection value**, with a flashing \* symbol indicating the setting item. Similarly, you can enter the desired protection limit

value in the numeric keypad area. If you want to clear and reset, you can press the **【Reset】** key and re-enter. At this point, pressing **【F3】** will switch back to the interface for setting output current and voltage. After completing the settings, press **【F4】** to confirm the output and start working.

Example: Set output voltage to 28.5V, output current to 10.5A, overvoltage protection to 29V, and overcurrent protection to 15A (values entered using the keypad).

Press **【F1】 【28.5】 【F2】 【10.5】 【F3】 【F1】 【29】 【F2】 【15】 【F4】** to complete the input, the power supply will start outputting and begin operation. At this point, the display screen will show various status information and output values of the power supply, and the 'ENTR' corresponding to F4 will change to 'STOP'.

To stop operation, press **【F4】** (corresponding to STOP), and the power supply will stop outputting.

**\*Note: When the overcurrent protection value is set to 0, the overcurrent protection function will be disabled.**

### 2.2-2 Output voltage and output current knob input (knob input method)

When the power supply is powered on, after pressing the power switch, the display screen will show normally. At this point, press the **【 Manual 】** button on the front panel (see front panel figure 9), the button indicator light will turn on, and the display screen will enter manual adjustment mode, as follows:

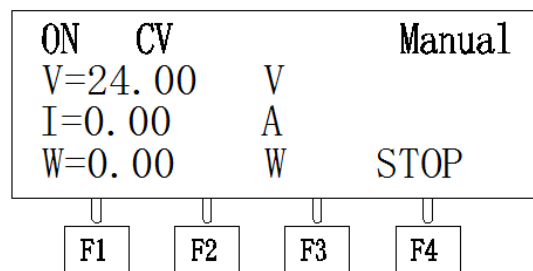

The display screen shows the power output status (On ON, Off OFF), operating status (Constant Voltage CV, Constant Current CC, Overvoltage OV),

output voltage V, output current A, output power W. Manual indicates manual adjustment.

Turning the voltage knob 10 and the current knob 11 clockwise can increase the output voltage value and output current value; turning them counterclockwise will have the opposite effect.

If you need to exit, press the button **【 F4 】** (corresponding to STOP) to exit the knob adjustment mode.

## 2.3 Storage/retrieval operation

### 2.3-1 Storage operation

Users can save some commonly used parameters in 6 groups of memory for quick retrieval. The stored content includes output voltage, output current value, and overvoltage and overcurrent values. Before storing, you must first set the required voltage, current, overvoltage, and overcurrent values (refer to section 2.2-1 for details).

Press 【 F2 】 (SAVE), the display screen will enter the storage interface, as shown below (example):

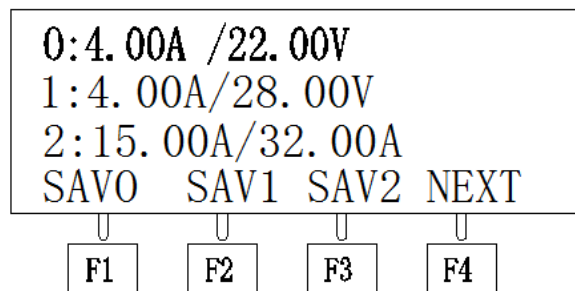

By pressing 【 F1 】 or 【 F2 】 or 【 F3 】 , select the value to save to group 0, group 1, or group 2. Press 【 F4 】 (NEXT) to switch the display as follows:

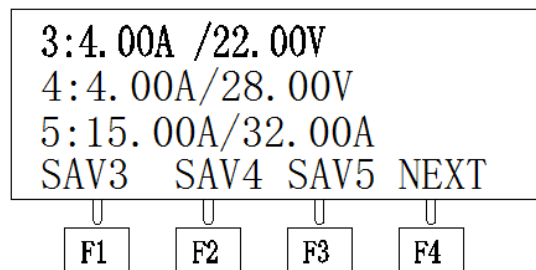

Similarly, by pressing 【 F1 】 or 【 F2 】 or 【 F3 】 , select to save to group 3, group 4, or group 5. In this example, select group 0 to save.

### 2.3-2 Retrieve operation

Power on the power supply, on the main interface display, press 【 F3 】 (RECL) to enter the retrieval of stored data, displaying as follows:

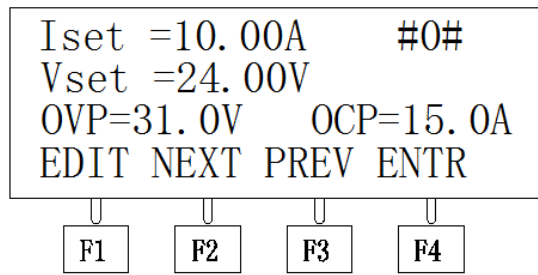

#0# indicates group 0

The LCD screen displays the output current value Iset, output voltage value Vset, overvoltage protection value OVP, and overcurrent protection value OCP.

By pressing 【 F2 】 (NEXT forward) or 【 F3 】 (PREV backward), you can enter different storage groups, with the group number indicated between # #.

After selecting the desired group, press 【 F4 】 (ENTR), and the power supply will start output based on the called parameter values.

\* If you need to modify the called values, you can press 【 F1 】 (EDIT) to enter the settings editing interface. After making the settings, return to the current retrieval interface, and the reset values will be saved.

## 2.4 Function Settings

### 2.4-1 Status value display

In the main interface state, press the function key 【 Display 】 to enter detailed value display, as follows

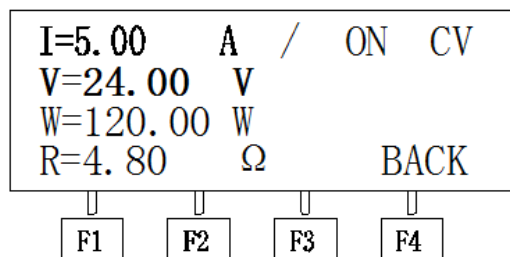

Current unit is Ampere A, voltage unit is Volt V, power unit is Watt W, resistance unit is Ohm  $\Omega$

ON CV indicates the power supply operating status: ON power output; OFF power stopped;



CV power supply constant voltage; CC power supply constant current; OV power supply overvoltage

To exit, press 【 F4 】 (BACK) key to return to the main interface.

### 2.4-2 Continuous time setting

The power supply provides power to the load, and the duration can be set. When the required output time is reached, it will automatically stop output and emit a buzzer sound as a reminder. Before setting the working hours, you must first set the required voltage, current, overvoltage, and overcurrent values (refer to section 2.2-1 for details). In the main interface, press the function key 【 Timer 】 to enter the working settings, which will display as follows

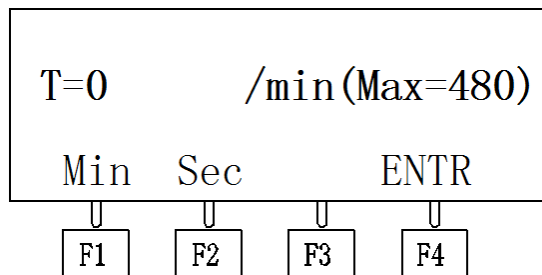

Min indicates minutes, with a maximum value of 480; Sec indicates seconds, with a maximum value of 3600. Select the time unit using 【 F1 】 or 【 F2 】.

For example, to input 8 minutes, press 【 F1 】 to select the unit as minutes, then enter the value 8 in the numeric keypad area, and continue by pressing 【 F4 】 (ENTR) to confirm the output, and the power supply will start working. The main interface will show a countdown prompt as follows

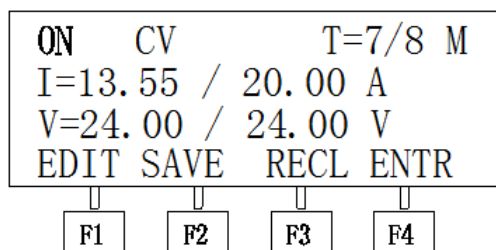

In the upper right corner, T=7/8, where 8 is the set working time and 7 is the remaining working time. When it reaches 8 minutes, the power supply stops outputting and emits a buzzer sound as a reminder.

### 2.4-3 Locking function

The locking function can prevent the power supply from being accidentally triggered during operation. When the power supply is operating on the main interface, press the function key **【 Lock 】**, the locking indicator will light up. At this time, only the Lock key can be pressed; any other key will be ineffective. Press **【Lock】** again to turn off the locking indicator and cancel the lock.

### 2.4-4 Overvoltage cancellation

If the power supply has a short interval between restarts, or if it switches from high voltage to low voltage, it may trigger overvoltage protection, and the OV indicator will light up. At this time, you can press the function key **【O.V】** to cancel the overvoltage protection.

If an abnormal voltage increase occurs, reset the parameter value and then press the O.V key to cancel the overvoltage protection.

## 2.5 Protection Function

This power supply provides protection functions for overvoltage, overcurrent, overpower, and overtemperature.

Overvoltage protection prevents damage to the product from excessively high voltage.

Overcurrent protection prevents abnormal conditions from causing excessive current, thereby canceling the output.

Overpower protection is a safety measure implemented when the power exceeds the maximum power of the instrument itself.

Overtemperature protection function: when the power supply operates at an abnormally high temperature, the instrument will automatically shut off the output to ensure safe use.

## 2.6 Operation Mode Description

### 2.6-1 Constant Voltage Operation Mode

- (1) Connect the load to the output terminals.

For safety during use, please connect the load to the output terminals (+) and (-) while the

output is turned off.

(2) Press 【 F1 】 to enter the parameter settings interface. In this mode, you can use the numeric keypad to input the desired output voltage value, output current value, overvoltage protection, and overcurrent protection value.

(3) After setting is complete, press 【 F4 】 to turn on the output. The display screen will show the main interface, displaying the actual measured values and status of the output.

(4) Confirm that this power supply is in constant voltage mode.

Please confirm the CV status indicator to ensure that the output operates in constant voltage operation mode. If the CC status indicator is on, increase the current setting value to ensure that the output operates in constant voltage operation mode.

### **2.6-2 Constant current operation mode**

(1) Connect the load to the output terminal.

For safety during use, please connect the load to the output terminals (+) and (-) while the output is turned off.

(2) Press 【 F1 】 to enter the parameter settings interface. In this mode, you can use the numeric keypad to input the required output voltage value, output current value, overvoltage protection, and overcurrent protection value.

(3) After setting is complete, press 【 F4 】 to turn on the output, the display screen will show the main interface, displaying the actual measured values and status of the output.

(4) Confirm that this power supply is in constant current mode.

Please confirm the CC status indicator to ensure the output operates in constant current operation mode. If the CV status indicator is on, increase the voltage setting value to ensure the output operates in constant current operation mode.

### **2.6-3 Constant voltage/constant current state switching**

In the output state, when the output current is less than the current setting value, the power supply is in constant voltage state, and the constant voltage indicator C.V is lit. The output voltage remains stable at the set value until the output current reaches the current setting value, at which point it enters constant current state, and the constant current indicator C.C is lit. The power supply automatically switches between constant voltage and constant current states based on the load.

## 2.7 Usage of Remote Compensation Function

When the power supply outputs current to the load, if the output current experiences excessive voltage drop along the output wire, for example, if the output is set to 24V, the voltage across the load may be 21V, resulting in a loss of 3V along the output wire. At this point, this function can be used to ensure that the voltage across the load remains at the set voltage, preventing variations due to reasons such as long wire lengths.

Refer to the rear panel diagram (Page 5), and use a flathead screwdriver to toggle the remote compensation switch ( ⑥ ), which is set to the left inside position by default from the factory. When in the inside position, the compensation function is disabled, and the remote compensation terminal ( ⑦ ) is left unconnected.

When the compensation function is needed, first turn off the power switch. At this time, use a screwdriver to toggle the remote compensation switch ( ⑥ ) to the right outside position. Use fine wires to connect the remote compensation terminal to the load, as shown in the diagram below:

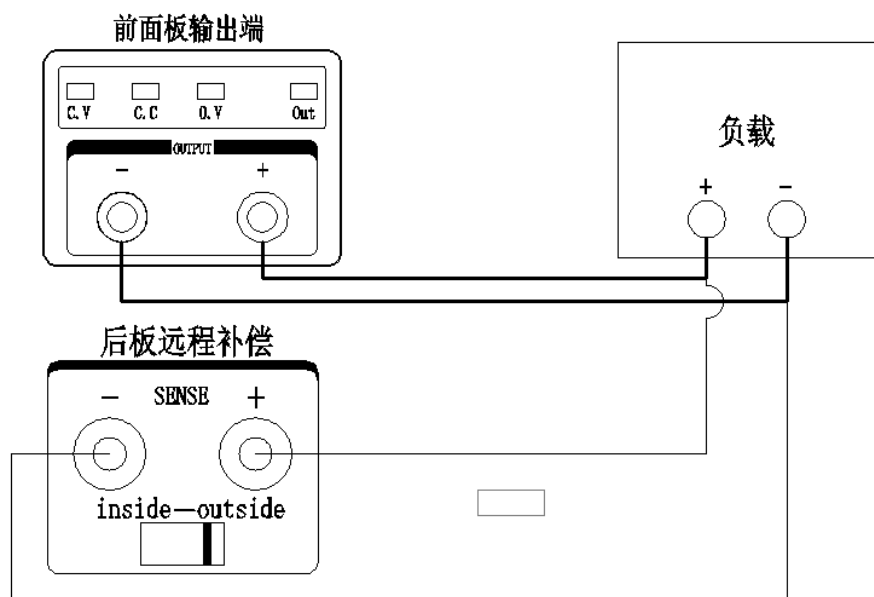

First, ensure that the load is securely connected to the positive and negative output terminals on the panel. Then, use fine wires to connect the remote compensation terminal on the rear panel to the positive and negative terminals on the load, inserting banana plugs into the terminals. The compensation switch must also be toggled to the outside position.

At this point, the device can be powered on for use.

Note: When using the remote compensation function, the load and output positive and negative terminals must be properly connected, and the rear panel compensation terminal must be connected to both ends of the load. The rear panel compensation terminal must not be left unconnected; otherwise, the voltage may continuously rise.

The voltage across the load and the voltage drop across the output wires, the sum of these two is the voltage at the output terminal. The overvoltage setting must be sufficiently high and cannot be lower than the output voltage; otherwise, overvoltage protection will be triggered.

### 3 Remote Control

This series of power supplies supports remote control and provides two interfaces, USB and 485, for communication with a computer. The upper computer software allows for the setting of voltage and current of the power supply, as well as start and stop functions, while also monitoring the voltage, current values, and status of the power supply in real-time.

#### 3.1 Interface

The front panel of the power supply is equipped with a USB interface, as shown in the figure below:

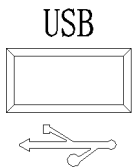

Note: Use a shielded USB cable to connect to the computer to enhance anti-interference.

The rear panel of the power supply is equipped with a 485 interface, as shown in the figure below:

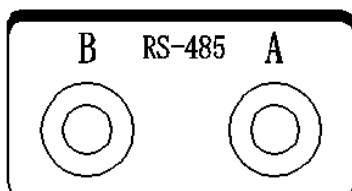

A, Terminal B is for the A and B ends of the 485 communication. Use a plug to connect to the 485 interface. If you need to connect to a computer, you can use a USB to RS485 converter. Connect as shown in the figure below:

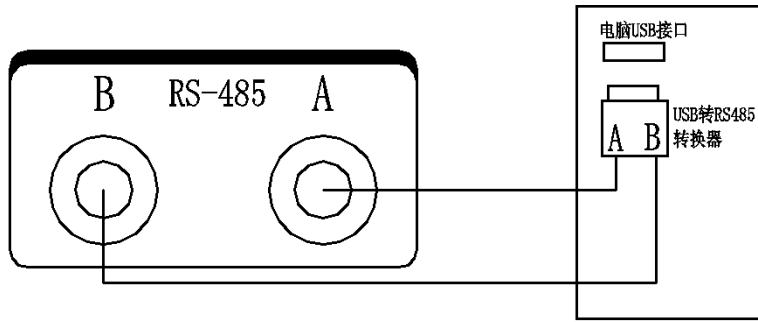

### 3.2 Communication Settings

Set the COM port in the PC according to the following settings:

- (1) Baud rate: 9600
- (2) Parity: None
- (3) Data bits: 8
- (4) Stop bits: 1

Note: If the power supply does not respond during remote control, please check:

- 1) Whether the interface cable is disconnected;
- 2) Whether the pins of the interface cable, power supply, and PC correspond correctly;
- 3) Whether the interface cable is securely connected;
- 4) Whether the communication parameters for remote control are consistent with the settings above;
- 5) Does the port number exceed COM16? If so, please change the port number;

### 3.3 Host Control Interface

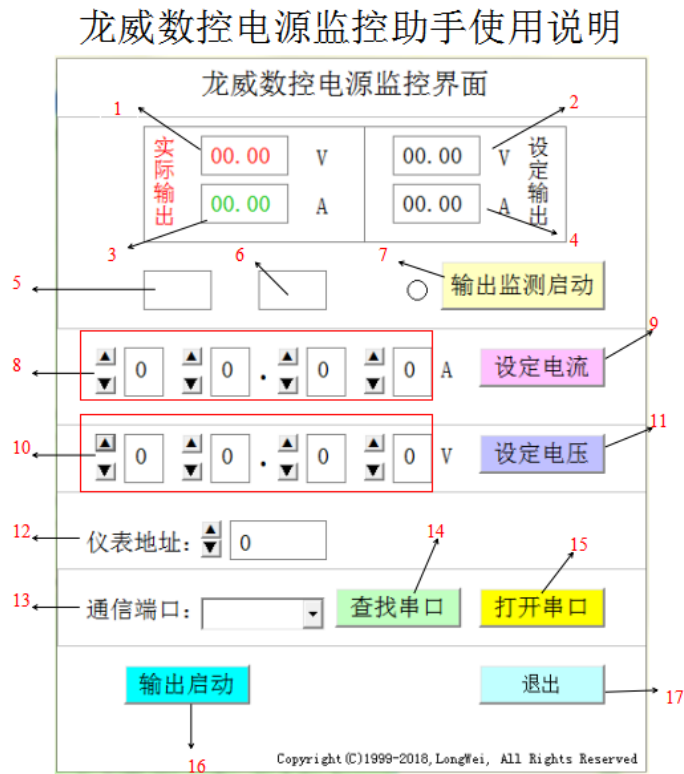

Through the host control software, you can control the output voltage and current of the power supply on the computer interface, start and stop the power supply output, and monitor the output voltage and current values of the power supply in real-time, as well as the status of the power supply: constant voltage or constant current overvoltage, and whether it is outputting.

For specific operational instructions, please refer to: Longwei CNC Power Supply Monitoring Assistant User Manual

### 3.4 Communication Format

Receiving: The power supply sends monitoring status data to the host via USB and 485 ports, averaging once every second.

The format is: V00.00A00.00P00, where P00 has the following 5 meanings

P01: Overvoltage OV status, output enabled

P11: Constant voltage CV status, output enabled

P21: Constant current CC status, output enabled

P00: Overvoltage OV status, output disabled

P10: Constant voltage CV status, output disabled

P20: Constant current CC status, output disabled

Complete format example: V24.00A12.55P11, meaning the power supply is currently outputting a voltage of 24.00V, an output current of 12.55A, in constant voltage mode, and the output is enabled

**Send:** The host can send function codes to the power supply, which will respond upon receipt. The function codes are as follows:

- ① V=00.00, for example V=12.00, the host controls the power supply to set the output voltage to 12.00V
- ② I=00.00, for example I=10.00, the host controls the power supply to set the output current to 10.00A
- ③ S=0, the main unit controls the power supply to turn off the output
- ④ S=1, the main unit controls the power supply to start the output

## 4 Common Faults Handling and Maintenance

Pressing the front panel voltage switch shows a black screen with no display:

1. Check if the voltage connector is properly connected
2. Check if the fuse is correct and intact.

Constant voltage output is abnormal:

1. Check if the maximum output power meets the load requirements.
2. If it meets, please check: see if the current setting is appropriate; if it is too low, you can appropriately increase the current setting value. Check if there is a short circuit or open circuit in the cable connecting the load and the power supply, and ensure good contact. Check if there is a problem with the load.

Constant current output is abnormal:



1. Check if the maximum output power meets the load requirements.
2. If satisfied, check whether the voltage setting value is appropriate; if too low, you can appropriately increase the voltage setting value. Check whether the cables connecting the load and the power supply have short circuits or disconnections, and whether the connections are good. Check if there is a problem with the load.

#### Fuse replacement

1. Disconnect the power supply and use a flathead screwdriver to remove the fuse holder.
2. Replace the fuse

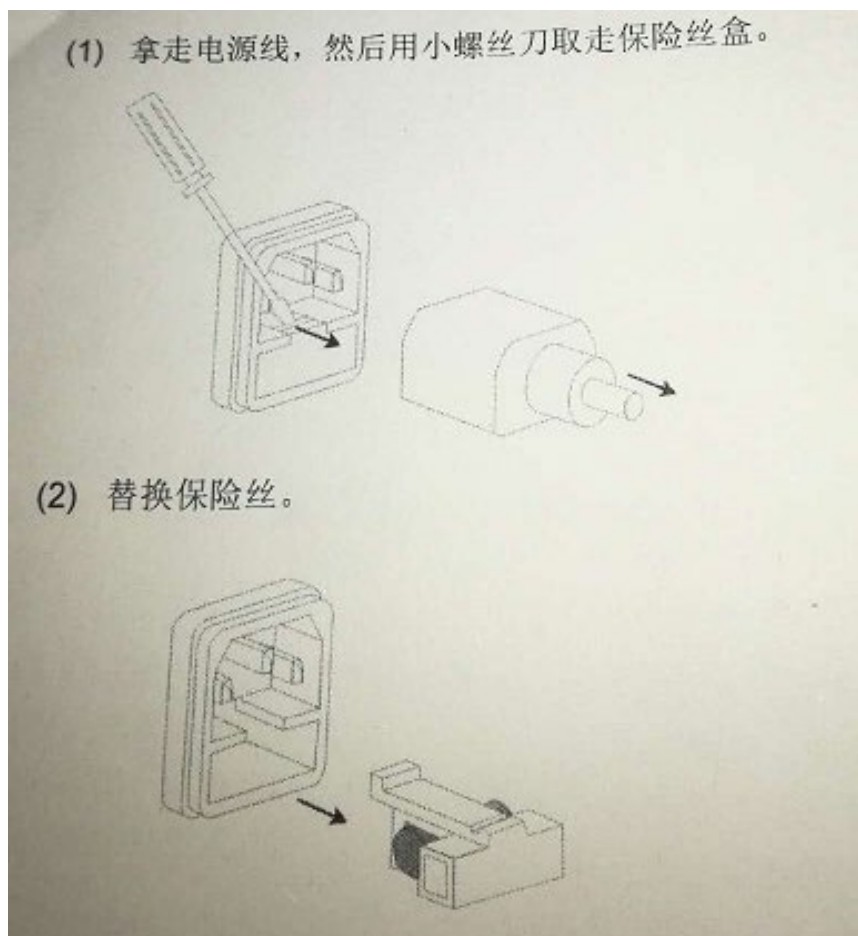

## 5 Monitoring Assistant Software User Instructions

### 龙威数控电源监控助手使用说明

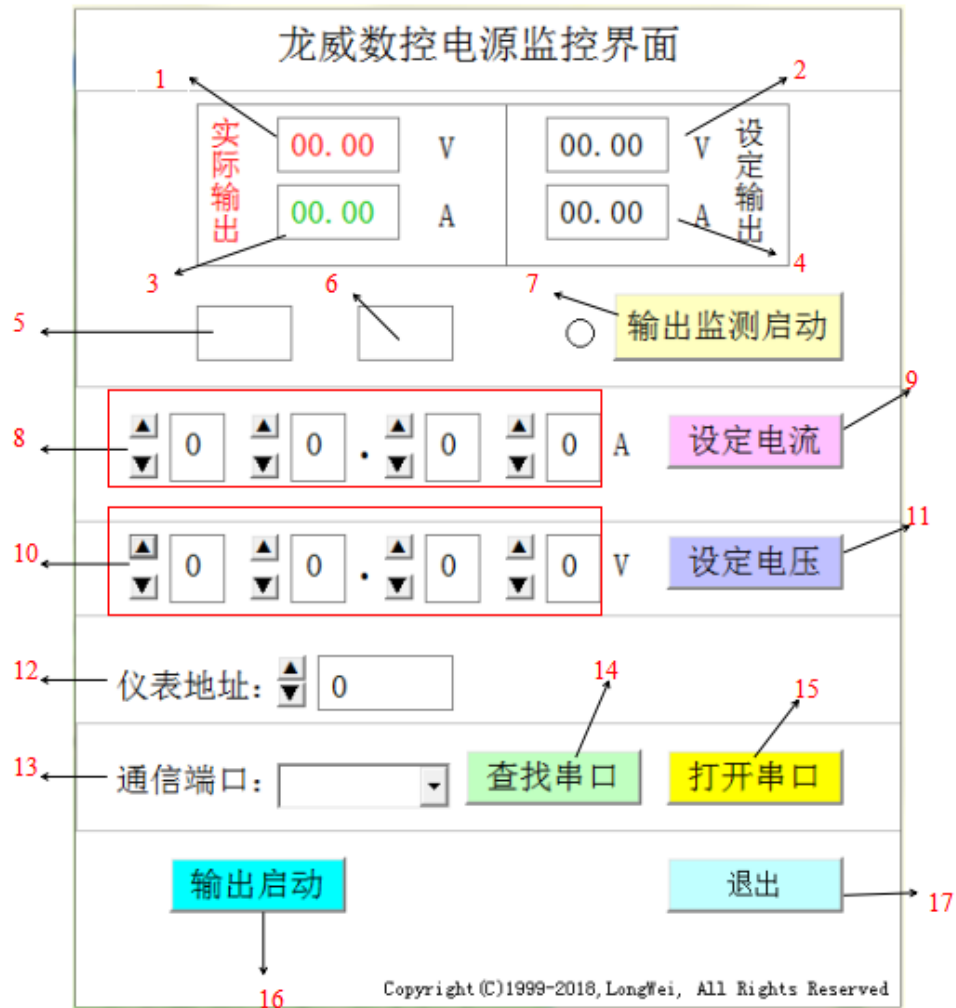

#### 1. Interface introduction

1. The actual output voltage value of the programmable power supply.
2. The set voltage value of the programmable power supply.
3. The actual output current value of the programmable power supply.
4. The set current value of the programmable power supply.
5. The status display of the programmable power supply, with three states: displaying 'CV' indicates constant voltage mode, displaying 'CC' indicates constant current mode, and displaying 'OV' indicates overvoltage mode.
6. Output status display; 'ON' indicates that the output has been started, while 'OFF' indicates that the output has stopped.

7. Output monitoring start button; clicking it once changes it to 'Output monitoring stop', at which point windows 1, 3, 5, and 6 will display information. Pressing it again will stop the monitoring, and the button will display 'Output monitoring start'; windows 5 and 6 will not show any information, and windows 1 and 3 will reset to zero.

8. Window for the set current value.

9. Set current button; pressing the button once allows you to set the desired current. If the serial port is open and the output is started, you can set the current for the programmable power supply. The programmable power supply can output the set current when it is loaded and short-circuited.

10. Window for the set voltage value.

11. Set the voltage by pressing the button; press the button to set the desired voltage. If the serial port is open and the output is started, the programmable power supply can be set to output the specified voltage.

12. Set the slave address for RS485 communication.

13. Display the port number. The port number is generally between COM1 and COM16; select the corresponding port number from the drop-down list.

14. Find the port number. Pressing the search button will display the available port numbers.

15. Open the serial port button; press to open the communication port, which will display 'Close Serial Port.' Press again to close the port, which will display 'Open Serial Port.'

16. Output start button; pressing it will display 'Output Stop,' and the programmable power supply will start outputting. Pressing it again will display 'Output Start,' and the programmable power supply will stop outputting.

17. Exit software button

## **II. Purpose**

This software is developed to work with a computer to monitor the Longwei programmable power supply, facilitating customers to better obtain the status and other data of the programmable power supply as well as control it.

## **III. Overview**

This software is a portable executable (exe) file that does not require installation and can be opened directly. The software is safe and free of viruses; if antivirus software flags it as a virus, please do not block it, or if it has been mistakenly blocked, please add it as a trusted file. The software is lightweight, consumes minimal memory, and is easy to operate.

The programmable power supply connects to the computer via USB or RS-485, and this software facilitates serial communication. The software can set the output voltage and current of the power supply, control the output

start and stop, and monitor the output changes of the power supply in real-time.

#### IV. Compatibility

The software can run on Windows XP and Windows 7 systems, but is not compatible with Windows 10 and other non-Windows systems.

#### V. Operating Instructions

##### 1. Serial Port Driver Installation

(1) We provide the driver in a folder named 'drivers'. Insert the USB data cable into the computer, open the 'drivers' folder, which contains two commonly used drivers. If your computer is a 32-bit system, whether it is Windows XP or Windows 7, double-click the file named dpinst-x86, which is the 32-bit driver. If your computer is 64-bit, double-click the file named dpinst-amd64. During the installation process, you must select 'Always trust'.

(2) Alternatively, if the computer prompts that new hardware has been found, the computer will pop up the 'Found New Hardware Wizard' dialog. Then select 'Install from a list or specified location', find the 'drivers' folder containing the driver, select that folder, and proceed with the installation.

##### 2. Open the serial port

After installing the driver, open the software, click 'Find Serial Port', the available port will display as COMA, where A is a number from 1 to 16. If A is greater than 16, you need to open the Device Manager on the computer,



find the port, right-click on Arduino Micro (COMA),

click on Port Settings, then select Advanced (A), and choose a COM port number from COM1 to COM16 **any unused port number**, then click OK.

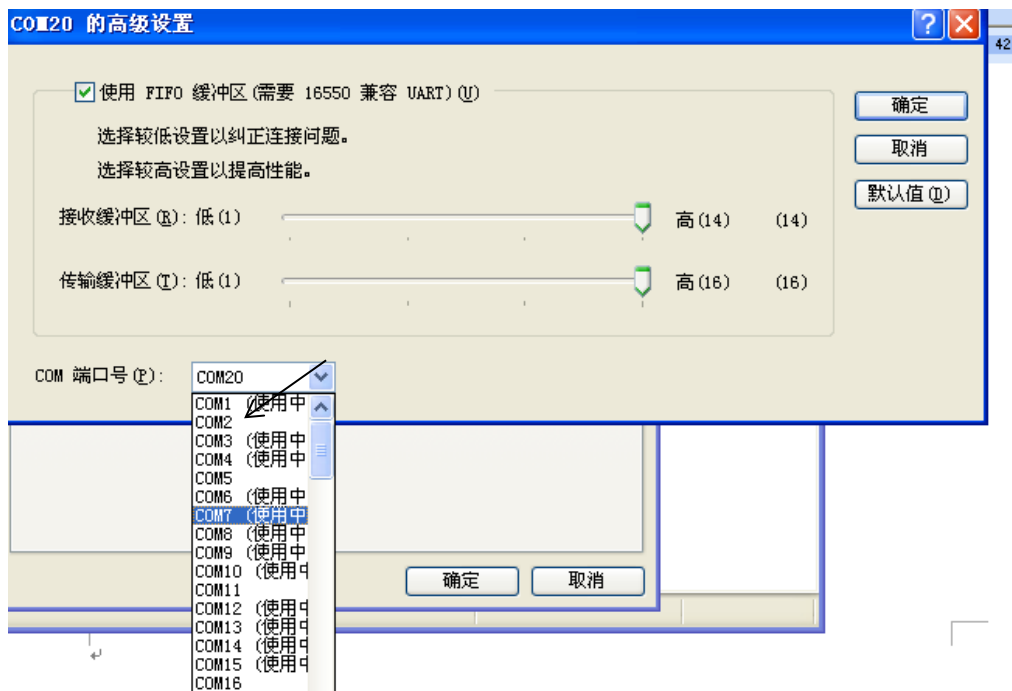

After making the changes, click 'Find Serial Port' in the software again, and finally click 'Open Serial Port'. Once successfully opened, it will display 'Port COMA has been opened' in the lower left corner.

### 3. Output start and stop

Once the serial port is opened, the computer establishes serial communication with the programmable power supply, and the software begins monitoring. If the programmable power supply has already started outputting, the output start button will change to 'Output Stop', and there is no need to click this button again. When it displays 'Output Stop', clicking this button will stop the output of the programmable power supply, changing the button back to 'Output Start'. If the programmable power supply has not started outputting, it will display 'Output Start' at this time, and clicking this button will start the output of the programmable power supply, changing the display to 'Output Stop'.

### 4. Set voltage and current

First, select the value of voltage or current on the left, open the serial port and output start, then click to set the voltage or current. At this point, the programmable power supply will set the voltage or current.

### 5. Start and stop output monitoring

After setting the voltage or current, click 'Start Output Monitoring'. The button will change to 'Stop Output Monitoring'. The top left corner of the software will display the actual output voltage and current of the programmable power supply, indicating whether it is in constant voltage, constant current, or overvoltage status.

## 6. Precautions and statements

1. Please use the software according to the operating instructions to reduce the likelihood of software bugs.

2. If a bug occurs, please close the software and restart it.
3. After opening the software, please first open the serial port before performing other operations. The 'Output start' will change to 'Output stop', allowing you to set the voltage and current.
4. Frequent data reception between the computer and the programmable power supply will occupy a certain amount of memory, causing some lag. Please do not open too many software applications to leave enough memory and prevent the software from becoming unresponsive or freezing.
5. The delay in the actual output display change after setting the voltage and current is due to the transmission time required for the programmable power supply to send data to the computer after receiving the set voltage command. This is not caused by software delay settings or slow response.
6. The USB data cable connecting the programmable power supply and the computer should generally not exceed 5 meters; extension devices can be added, and the 485 data cable should not exceed 1 kilometer. A maximum of 128 programmable power supplies can be connected using the 485 data cable.

## **7. Frequently Asked Questions**

1. If the driver still fails to install successfully, please download the driver for the Arduino Genuine MICRO board and install it yourself.
2. If you cannot find or open the serial port, please refer to the instructions in the operation manual for opening the serial port. If the Arduino Micro (COMA) suddenly disappears or is not detected, please restart the computer.
3. If none of the above methods work, please try using a different USB data cable or 485 data cable.